

# SEMINATRICE

**PER MTZ 100-120-135-150-170**  
**MTZ<sub>HI</sub> 100-120-135-150-170**

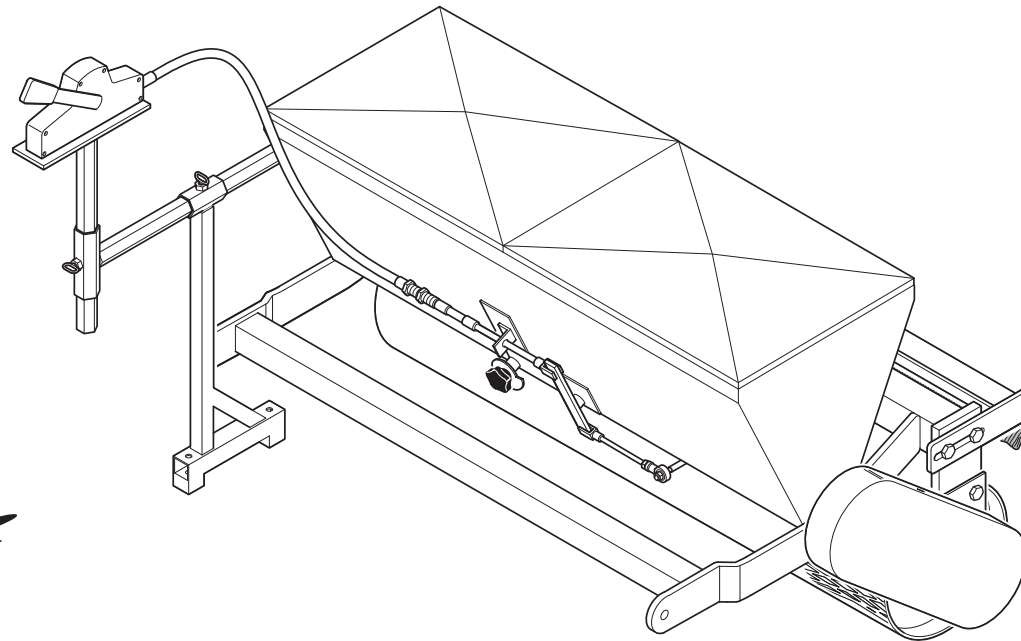

**R2 s.a.s. di Rinaldi Roberto & C.**

40060 Toscanella di Dozza (Bologna) Italy - Via Valsellustra, 25-29  
Tel. +39.0542.672100 • Fax +39.0542.674391

CATALOGO PARTI DI RICAMBIO  
SPARE PARTS CATALOGUE  
CATALOGUE DE PIECES DETACHEES  
ERSATZTEILKATALOG  
CATALOGO DE PIEZAS DE REPUESTO

Cod. 036 rev.0

Edizione 06/2008

**SIMBOLOGIA • SYMBOLS • SYMBOLES UTILISES • SYMBOLE • SIMBOLOGIA**

**I**

Nella colonna CODICE di ogni distinta può essere presente uno di questi simboli:



Parte di ricambio momentaneamente priva di codice.

Per identificarla occorre indicare:

- Numero della tavola
- Numero di posizione
- Modello e matricola della macchina.



Parte di ricambio avente ulteriori parti di ricambio interne.

Per identificare le singole parti interne occorre andare alla tavola di corrispondente denominazione.



Parte di ricambio con variabili dimensionali o di quantità.

Occorre specificare il modello e la matricola della macchina individuali nell'apposita targhetta.

**GB**

In the CODED column of each list, you find one of following symbols:



Spare part temporarily uncoded.

To identify the part you must specify:

- Table code
- Position number
- Machine model and serial number.



Spare part consisting of more internal spare parts.

To find the single internal parts, please refer to the relevant description table.



Spare part with dimension or quantity variables.

Always specify the machine model and serial number, given in the identification plate.

**F**

Dans la colonne CODE de chaque liste Vous pouvez trouver un des symboles suivants:



Pièce de réchange temporairement sans code.

Pour son identification, il faut spécifier:

- Code du tableau
- Numéro de position
- Modèle et numéro de fabrication machine.



Pièce de réchange comprenant des pièces de rechange à l'intérieur.

Pour l'identification de pièces individuelles, se référer au tableau descriptif correspondant.



Pièce détachée avec variables dimensionnelles o de quantité.

Spécifier toujours le modèle et le numéro de fabrication de la machine, donnés sur la plaque d'identification.

**D**

Die Reihe Anmerkungen jeder CODE kann eins folgender Symbole zeigen:



Ersatzteil hat vorübergehend keinen Code.

Um diesen Ersatzteil angeben zu können, müssen Sie:

- Code Tabelle
- Positionsnummer
- Maschinenmodell und -kennnummer.



Ersatzteil hat weitere Ersatzteile auf der Innenseite.

Für die Identifikation der einzelnen Innerteile, die entsprechende Benennungstabelle nachschlagen.



Ersatzteil mit variablen Maßen oder Menge.

Bitte, Modell und Fabriknummer der Maschine, die auf dem Typenschild abgedruckt sind, angeben.

**E**

La columna CÓDIGO de cada lista puede presentar uno de los símbolos siguientes:



Repuesto actualmente falto de código.

Para la identificación del repuesto es necesario indicar:

- Código tabla
- Número de posición
- Modelo y número de serie máquina.



Ruesto que consta de sucesivos repuestos internos.

Para la identificación de las partes internas distintas, ver tabla descriptiva correspondiente.



Repuesto con variables dimensionales o de cantidad.

Declarar siempre el modelo y el número de serie de la máquina, que se encuentran en la tarjeta de identificación.

**COME ORDINARE I RICAMBI • HOW TO ORDER SPARE PARTS • COMMANDE DES PIÈCES DÉTACHÉES •  
ANFRANGE VON ERSATZTEILEN • PEDIDO DE LOS REPUESTOS**

---

Per ordinare le parti di ricambio Vi preghiamo cortesemente di fornire al Servizio Assistenza tutte le seguenti informazioni:

- Modello, tipo e numero di matricola della macchina.
- Codice, descrizione e quantità delle parti di ricambio che si intendono ordinare.

Inoltre all'ordine sarà necessario precisare:

- Ragione sociale, indirizzo completo, recapito telefonico e telefax.
- Indirizzo completo al quale spedire le parti di ricambio.
- Eventuale mezzo di trasporto/vettore da utilizzare preferenzialmente.

When ordering spare parts, please supply After Sales Service the following information:

- Machine model, type and serial number
- Code, description and quantity of the spare parts you wish to order.

In addition to what above, add also:

- Corporate name, address, phone and fax number.
- Delivery address.
- Preferential transport mean/carrier.

Pour commander les pièces de rechange nous vous prions de bien vouloir transmettre au Service Après-Vente les indications suivantes:

- Modèle, type et numéro de série de la machine.
- Code, description et quantité des pièces de rechange commandées.

De plus, indiquer dans la commande:

- Nom de la société, adresse complète, numéro de téléphone et de télécopieur.
- Adresse complète pour l'expédition.
- Eventuel moyen de transport/expéditeur préférentiel.

Um Ersatzteil zu bestellen, bitten wir Sie höflichst, dem Kundendienst alle nachfolgend angeführten Angaben zu machen:

- Modell, Typ und Matrikel-Nr. der Maschine.
- Code, Beschreibung und Anzahl der Ersatzteile, die man bestellen möchte.

Außerdem sollte man bei der Bestellung angeben:

- Name der Firma, vollständige Adresse, Telefon und Fax-nummer.
- Vollständige Adresse, an die Ersatzteile zu senden sind.
- Von Ihnen gewünschtes Transportmittel / Transportunternehmen.

Para el pedido de repuestos, Le rogamos se sirvan suministrar al Servicio Asistencia todas las indicaciones siguientes:

- Modelo, tipo y número de matrícula de la máquina.
- Código, descripción y cantidad de los repuestos pedido.

Además, se ruega detallar lo siguiente:

- Razón social, dirección completa, teléfono y telefax.
- Dirección completa a la que se deben enviar los repuestos.
- Eventual medio/agente de transporte que se desea utilizar.

**INDICE DELLE TAVOLE • TABLE INDEX • INDEX DES TABLEAUX**

---

01.0	CASSONETTO SEMINATRICE (SM 100)	SEEDER BOX (SM 100)	CAISSON SEMOIR (SM 100)
02.0	CASSONETTO SEMINATRICE (SM 120-135-150-170)	SEEDER BOX (SM 120-135-150-170)	CAISSON SEMOIR (SM 120-135-150-170)
03.0	MONTAGGIO RULLO POSTERIORE (SM 100-120)	REAR ROLLER ASSEMBLY (SM 100-120)	MONTAGE ROULEAUX ARRIERE (SM 100-120)
04.0	MONTAGGIO RULLO POSTERIORE (SM 135-150-170)	REAR ROLLER ASSEMBLY (SM 135-150-170)	MONTAGE ROULEAUX ARRIERE (SM 135-150-170)
05.0	COMANDI OPERATORE	OPERATION CONTROLS	COMMANDES OPERATEUR

## TABELLEN-VERZEICHNIS • INDICE DE LAS TABLAS

---

01.0	KASTEN DRILLMASCHINE (SM 100)	CAJA SEMBRADORA (SM 100)
02.0	KASTEN DRILLMASCHINE (SM 120-135-150-170)	CAJA SEMBRADORA (SM 120-135-150-170)
03.0	MONTAGE HINTERE ROLLEN (SM 100-120)	MONTAGE RODILLOS TRASERO (SM 100-120)
04.0	MONTAGE HINTERE ROLLEN (SM 135-150-170)	MONTAGE RODILLOS TRASERO (SM 135-150-170)
05.0	BEDIENERSTEUERUNGEN	MANDOS OPERADOR



CASSONETTO SEMINATRICE (SM 100)  
SEEDER BOX (SM 100)  
CAISSON SEMOIR (SM 100)  
KASTEN DRILLMASCHINE (SM 100)  
CAJA SEMBRADORA (SM 100)

MTZ / MTZ<sub>HI</sub>

Tav. 01.0

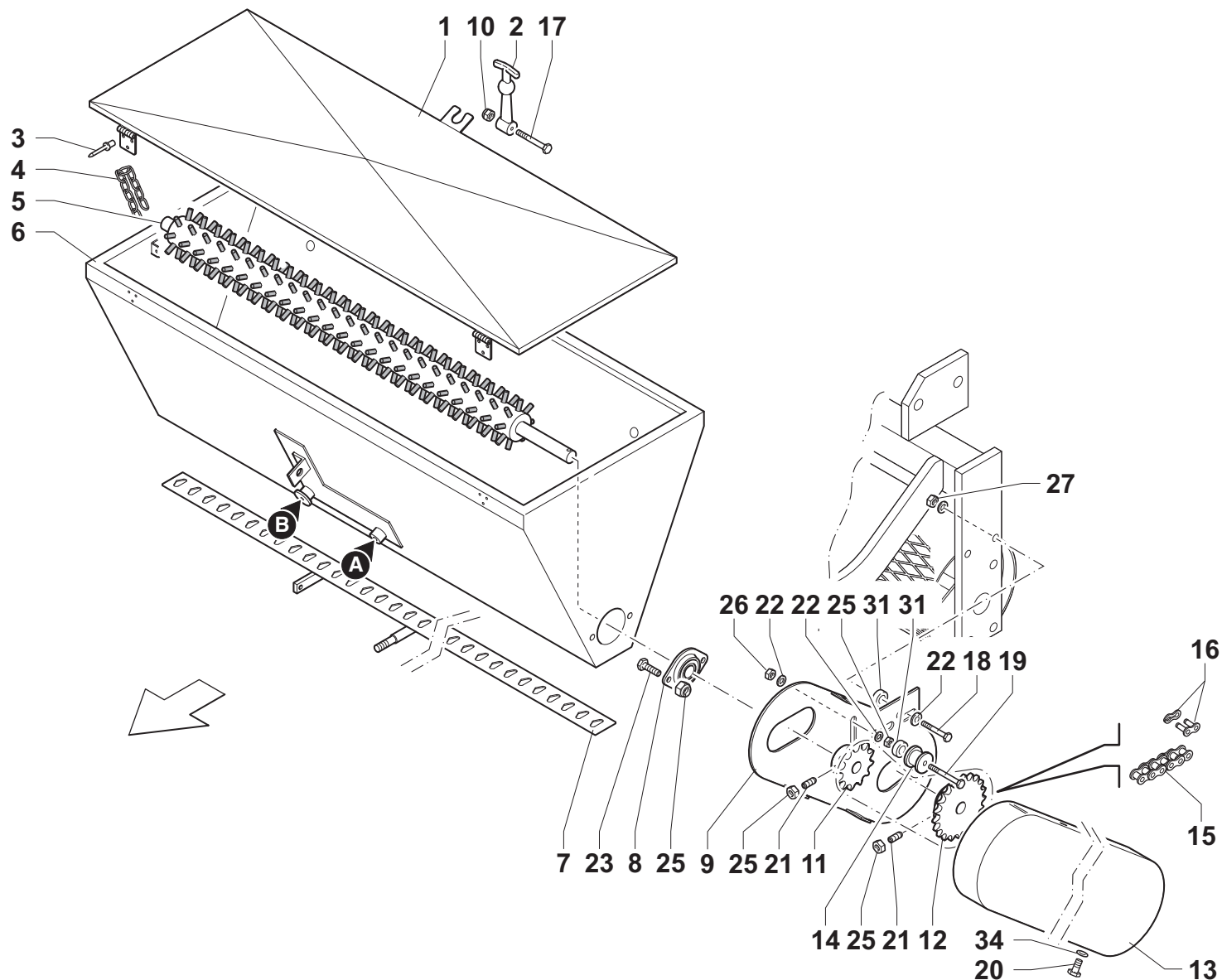
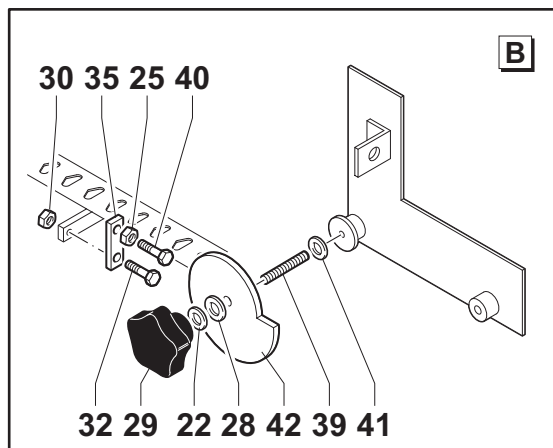
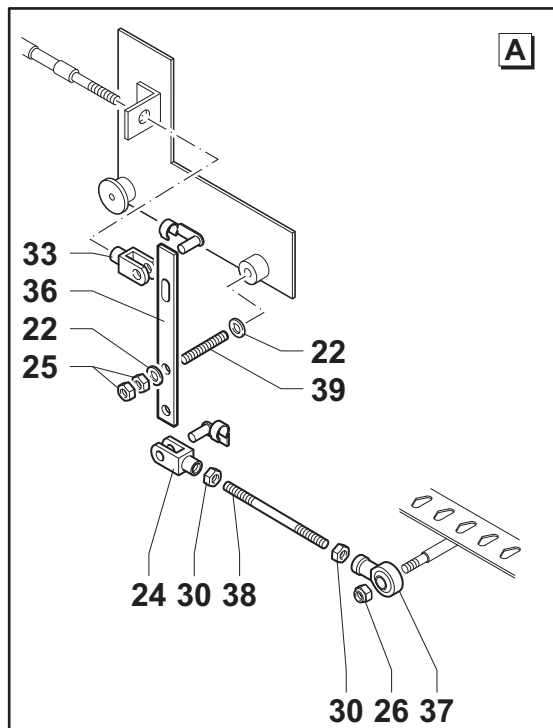

<b>Rif.</b>	<b>CODICE</b>	<b>Qty</b>	<b>Descrizione</b>	<b>Description</b>	<b>Designation</b>	<b>Benennung</b>	<b>Denominaciones</b>
1	036.002/A	1	COPERCHIO	COVER	COUVERCLE	DECKEL	TAPA
2	050.066	1	TIRANTE IN GOMMA	RUBBER TIE-ROG	TIRANT CAOUTCHOUC	GUMMI-ZUGSTANGE	TIRANTE DE GOMA
3		6	RIVETTO	RIVET	RIVET	NIETVERBINDUNG	REMACHE
4		1	CATENA	CHAIN	CHAÎNE	KETTE	CADENA
5	036.055	1	SPAZZOLA CASSONETTO	BOX BRUSH	BROSSE CAISSON	BÜRSTE KASTEN	CEPILLO CAJA
6	036.002/Z	1	CASSONETTO SEMINATRICE	SEEDER BOX	CAISSON SEMOIR	KASTEN DRILLMASCHINE	CAJA SEMBRADORA
7	036.002/C	1	BANDELLA CASSONETTO	BOX BAR	RABAT CAISSON	KASTENBAND	BANDA CAJA
8	BUPFL204	2	SUPPORTO	SUPPORT	SUPPORT	LAGER	SOPORTE
9	036.083	1	CARTER INTERNO CATENA	INTERNAL COVER FOR	CARTER INTERIEUR	INNERE SCHUTZABDECKUNG	CÁRTER INTERIOR CADENA
10	30.02.00.004	1	DADO AUTOBLOCCANTE	STOP NUT	ECROU DE SURETE	SPERRMUTTER	TUERCA AUTOTRABADORA
11	036.082	1	PIGNONE	PINION	PIGNON	RITZEL	PINON
12	036.081	1	CORONA	RING GEAR	COURONNE	KRANZ	CORONA
13	036.083/A	1	CARTER ESTERNO	EXTERNAL COVER FOR	CARTER EXTERIEUR	AUSSERE SCHUTZABDECKUNG	CÁRTER EXTERIOR CADENA
14	090.036	1	RULLO	ROLLER	ROULEAU	WALZE ROLLE	RODILLO
15	050.075	1	CATENA	CHAIN	CHAÎNE	KETTE	CADENA
16	050.076	1	MAGLIA DI GIUNZIONE	CHAIN JOINT	JOINT DE CHAÎNE	STECKGLIED	UNIÓN DE CADENA
17	21.0.0.04035	1	VITE	SCREW	VIS	SCHRAUBE	TORNILLO
18	20.0.0.08040	2	VITE	SCREW	VIS	SCHRAUBE	TORNILLO
19	20.0.0.08055	1	VITE	SCREW	VIS	SCHRAUBE	TORNILLO
20	21.0.0.05016	1	VITE	SCREW	VIS	SCHRAUBE	TORNILLO
21	25.2.1.08020	2	GRANO	SECURITY DOWEL	GRAIN	STIFT	PERNO DE TOPE
22	15.1.0.00.008	6	RONDELLA PIANA	PLAIN WASHER	RONDELLE PLANE	ABSTANDSRING	ARANDELA LLANA
23	21.0.0.08016	4	VITE	SCREW	VIS	SCHRAUBE	TORNILLO
24	050.069	2	FORCELLA	FORK	FOURCHE	GABEL	HORQUILLA
25	31.02.00.0.08	8	DADO	NUT	ECROU	MUTTER	TUERCA
26	30.02.01.008	1	DADO AUTOBLOCCANTE	STOP NUT	ECROU DE SURETE	SPERRMUTTER	TUERCA AUTOTRABADORA
27	30.02.00.008	2	DADO AUTOBLOCCANTE	STOP NUT	ECROU DE SURETE	SPERRMUTTER	TUERCA AUTOTRABADORA
28	050.071	1	RONDELLA TEFLON	TEFLON WASHER	RONDELLE TEFLON	TEFLON-SCHEIBE	ARANDELA TEFLON
29	050.030	1	POMELLO	BALL-GRIP	POMMEAU	KUGELGRIFF	POMO
30	31.02.00.008	5	DADO	NUT	ECROU	MUTTER	TUERCA
31	036.205	1	DISTANZIALE	SPACER	ENTRETOISE	ABSTANDSTUECK	SEPARADOR





CASSONETTO SEMINATRICE (SM 100)  
SEEDER BOX (SM 100)  
CAISSON SEMOIR (SM 100)  
KASTEN DRILLMASCHINE (SM 100)  
CAJA SEMBRADORA (SM 100)

MTZ / MTZ<sub>HI</sub>

Tav. 01.0

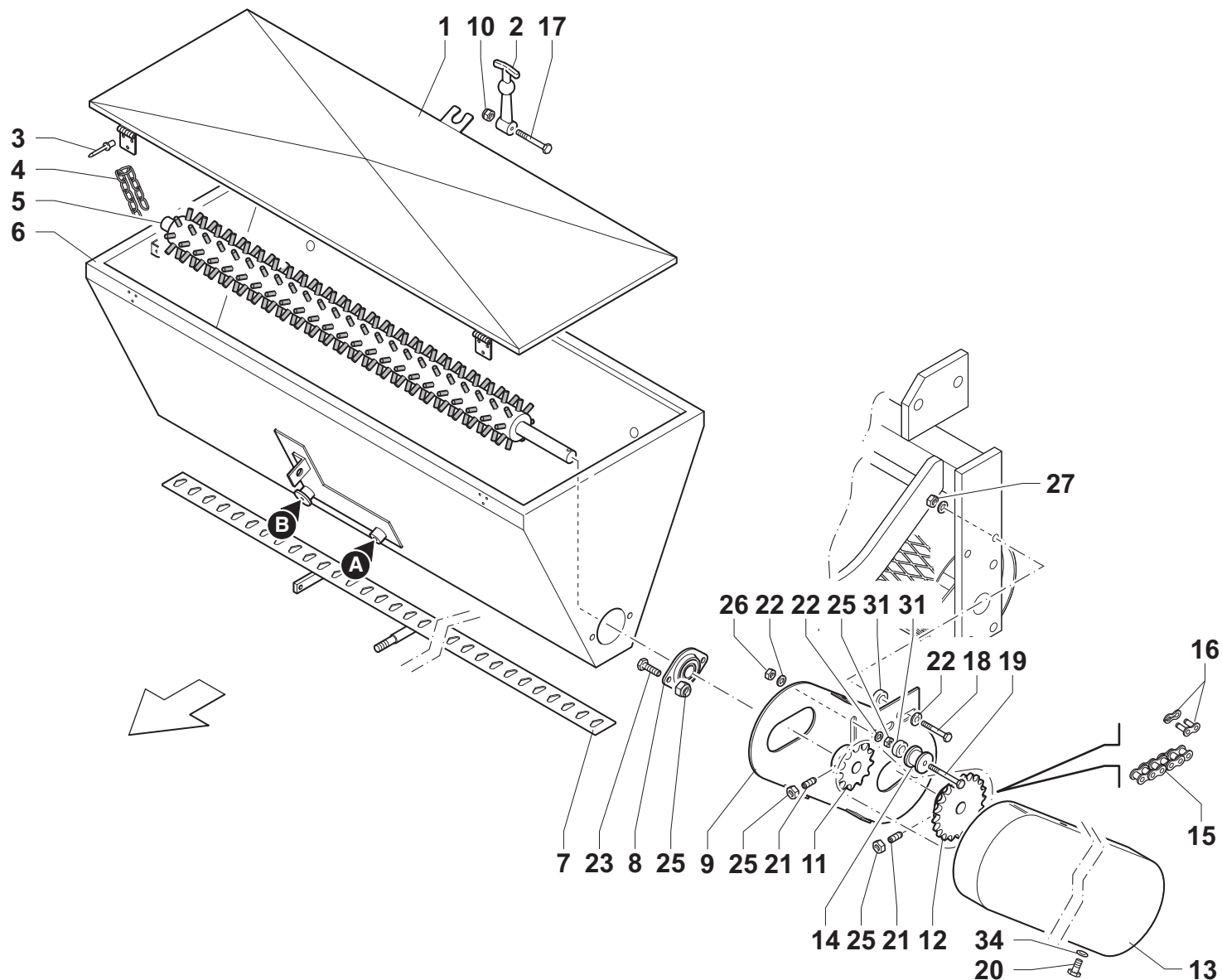
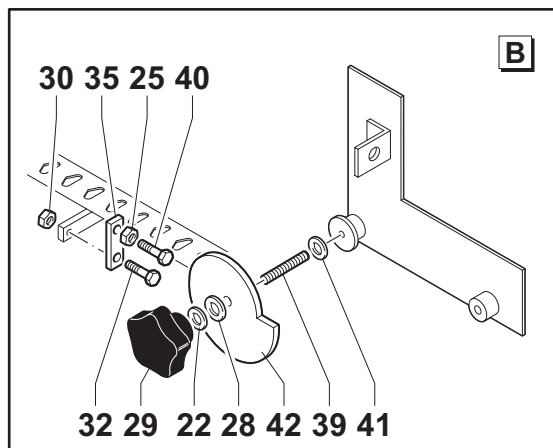
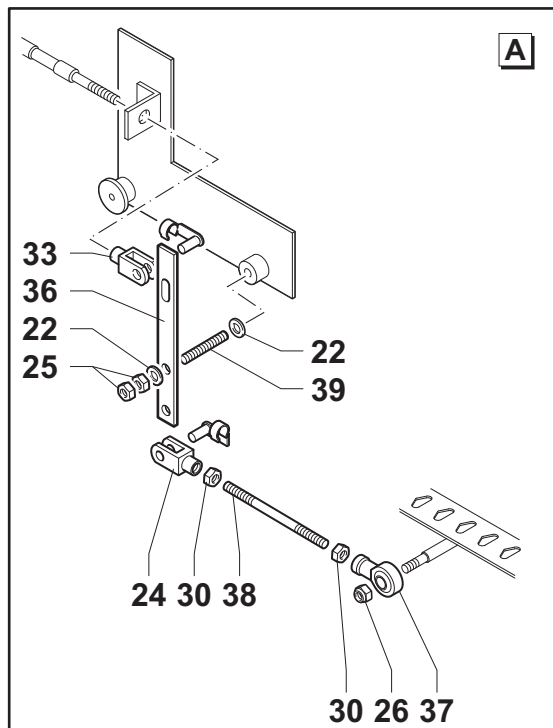







**CASSONETTO SEMINATRICE (SM 120-135-150-170)**  
SEEDER BOX (SM 120-135-150-170)  
CAISSON SEMOIR (SM 120-135-150-170)  
KASTEN DRILLMASCHINE (SM 120-135-150-170)  
CAJA SEMBRADORA (SM 120-135-150-170)

MTZ / MTZ<sup>HI</sup>

**Tav. 02.0**

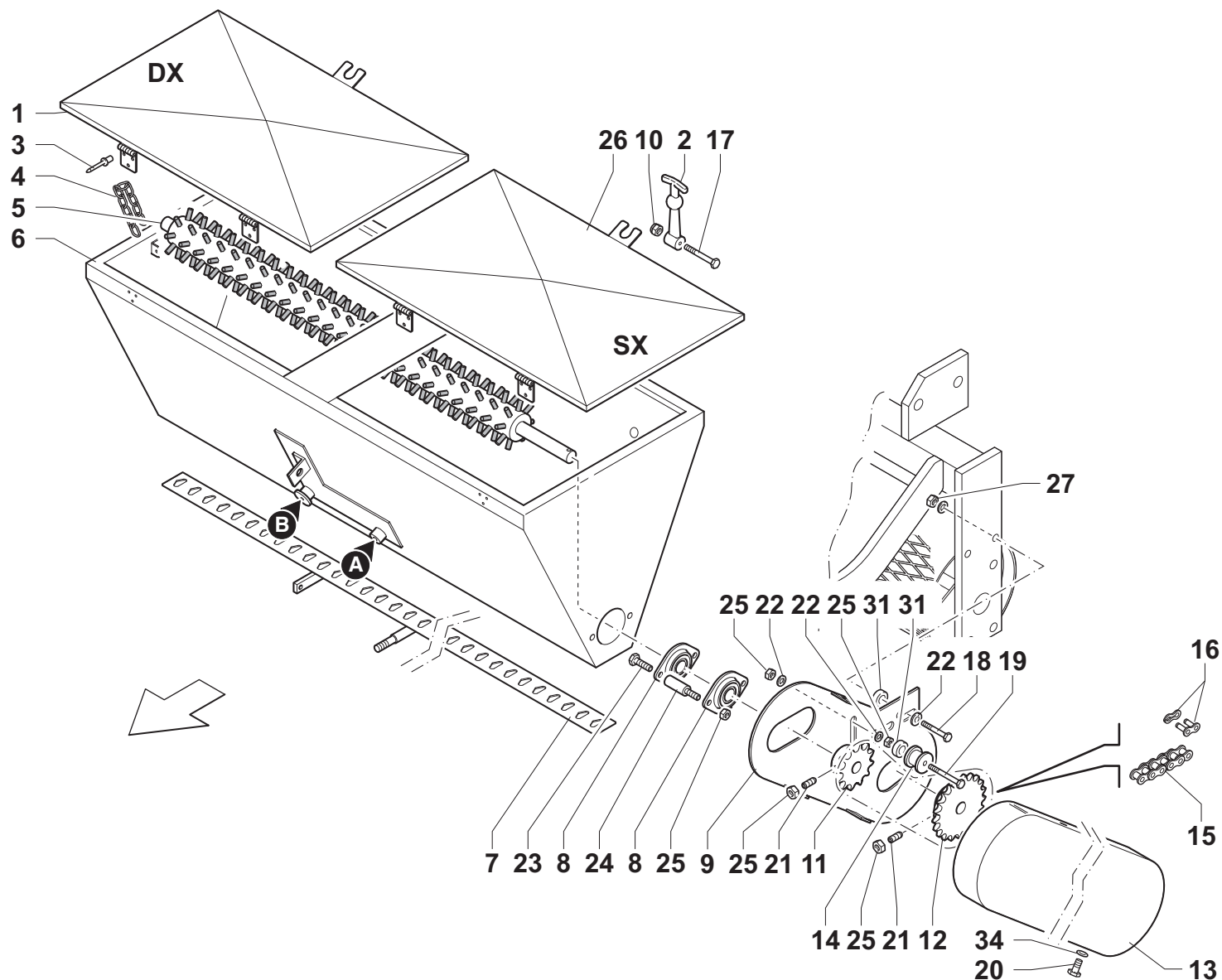
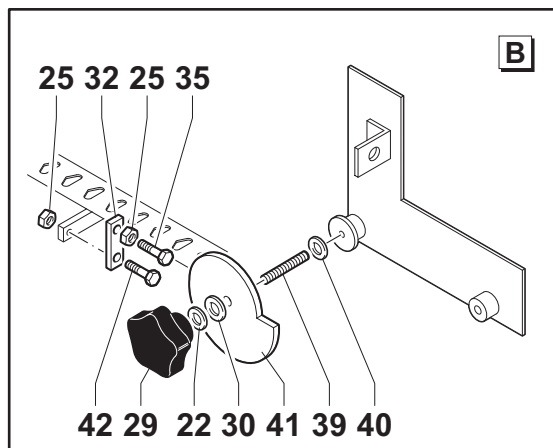
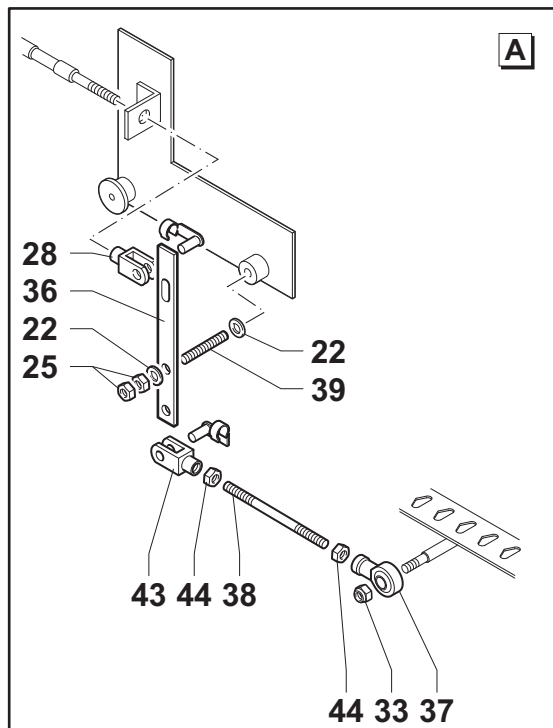

<i>Rif.</i>	<i>CODICE</i>	<i>Qty</i>	<i>Descrizione</i>	<i>Description</i>	<i>Designation</i>	<i>Benennung</i>	<i>Denominaciones</i>
1	036.004/DX	2	COPERCHIO SM-120	COVER	COUVERCLE	DECKEL	TAPA
1	036.006/DX	2	COPERCHIO SM-135	COVER	COUVERCLE	DECKEL	TAPA
1	036.138/DX	2	COPERCHIO SM-150	COVER	COUVERCLE	DECKEL	TAPA
1	036.142/DX	2	COPERCHIO SM-170	COVER	COUVERCLE	DECKEL	TAPA
2	050.066	2	TIRANTE IN GOMMA	RUBBER TIE-ROG	TIRANT CAOUTCHOUC	GUMMI-ZUGSTANGE	TIRANTE DE GOMA
3		12	RIVETTO	RIVET	RIVET	NIETVERBINDUNG	REMACHE
4		2	CATENA	CHAIN	CHAÎNE	KETTE	CADENA
5	036.055	1	SPAZZOLA SM-120	BOX BRUSH	BROSSE CAISSON	BÜRSTE KASTEN	CEPILLO CAJA
5	036.056	1	SPAZZOLA SM-135	BOX BRUSH	BROSSE CAISSON	BÜRSTE KASTEN	CEPILLO CAJA
5	036.057	1	SPAZZOLA SM-150	BOX BRUSH	BROSSE CAISSON	BÜRSTE KASTEN	CEPILLO CAJA
5	036.058	1	SPAZZOLA SM-170	BOX BRUSH	BROSSE CAISSON	BÜRSTE KASTEN	CEPILLO CAJA
6	036.004	1	CASSONETTO SM-120	SEEDER BOX	CAISSON SEMOIR	KASTEN DRILLMASCHINE	CAJA SEMBRADORA
6	036.006	1	CASSONETTO SM-135	SEEDER BOX	CAISSON SEMOIR	KASTEN DRILLMASCHINE	CAJA SEMBRADORA
6	036.138	1	CASSONETTO SM-150	SEEDER BOX	CAISSON SEMOIR	KASTEN DRILLMASCHINE	CAJA SEMBRADORA
6	036.142	1	CASSONETTO SM-170	SEEDER BOX	CAISSON SEMOIR	KASTEN DRILLMASCHINE	CAJA SEMBRADORA
7	036.004/B	1	BANDELLA SM-120	BOX BAR	RABAT CAISSON	KASTENBAND	BANDA CAJA
7	036.006/B	1	BANDELLA SM-135	BOX BAR	RABAT CAISSON	KASTENBAND	BANDA CAJA
7	036.138/B	1	BANDELLA SM-150	BOX BAR	RABAT CAISSON	KASTENBAND	BANDA CAJA
7	036.142/B	1	BANDELLA SM-170	BOX BAR	RABAT CAISSON	KASTENBAND	BANDA CAJA
8	BUPFL204	3	SUPPORTO	SUPPORT	SUPPORT	LAGER	SOPORTE
9	036.096/B	1	CARTER INTERNO CATENA	INTERNAL COVER FOR	CARTER INTERIEUR	INNERE SCHUTZABDECKUNG	CÁRTER INTERIOR CADENA
10	30.02.00.004	2	DADO AUTOBLOCCANTE	STOP NUT	ECROU DE SURETE	SPERRMUTTER	TUERCA AUTOTRABADORA
11	036.082	1	PIGNONE	PINION	PIGNON	RITZEL	PINON
12	036.081	1	CORONA	RING GEAR	COURONNE	KRANZ	CORONA
13	036.096/A	1	CARTER ESTERNO	EXTERNAL COVER FOR	CARTER EXTERIEUR	AUSSERE SCHUTZABDECKUNG	CÁRTER EXTERIOR CADENA
14	090.036	1	RULLO	ROLLER	ROULEAU	WALZE ROLLE	RODILLO
15	050.075	1	CATENA	CHAIN	CHAÎNE	KETTE	CADENA
16	050.076	1	MAGLIA DI GIUNZIONE	CHAIN JOINT	JOINT DE CHAÎNE	STECKGLIED	UNIÓN DE CADENA
17	21.0.0.04035	2	VITE	SCREW	VIS	SCHRAUBE	TORNILLO
18	20.0.0.08040	2	VITE	SCREW	VIS	SCHRAUBE	TORNILLO
19	20.0.0.08055	1	VITE	SCREW	VIS	SCHRAUBE	TORNILLO



MTZ / MTZ<sub>HI</sub>

**Tav. 02.0**



**CASSONETTO SEMINATRICE (SM 120-135-150-170)**  
SEEDER BOX (SM 120-135-150-170)  
CAISSON SEMOIR (SM 120-135-150-170)  
KASTEN DRILLMASCHINE (SM 120-135-150-170)  
CAJA SEMBRADORA (SM 120-135-150-170)

MTZ / MTZ<sup>HI</sup>

**Tav. 02.0**

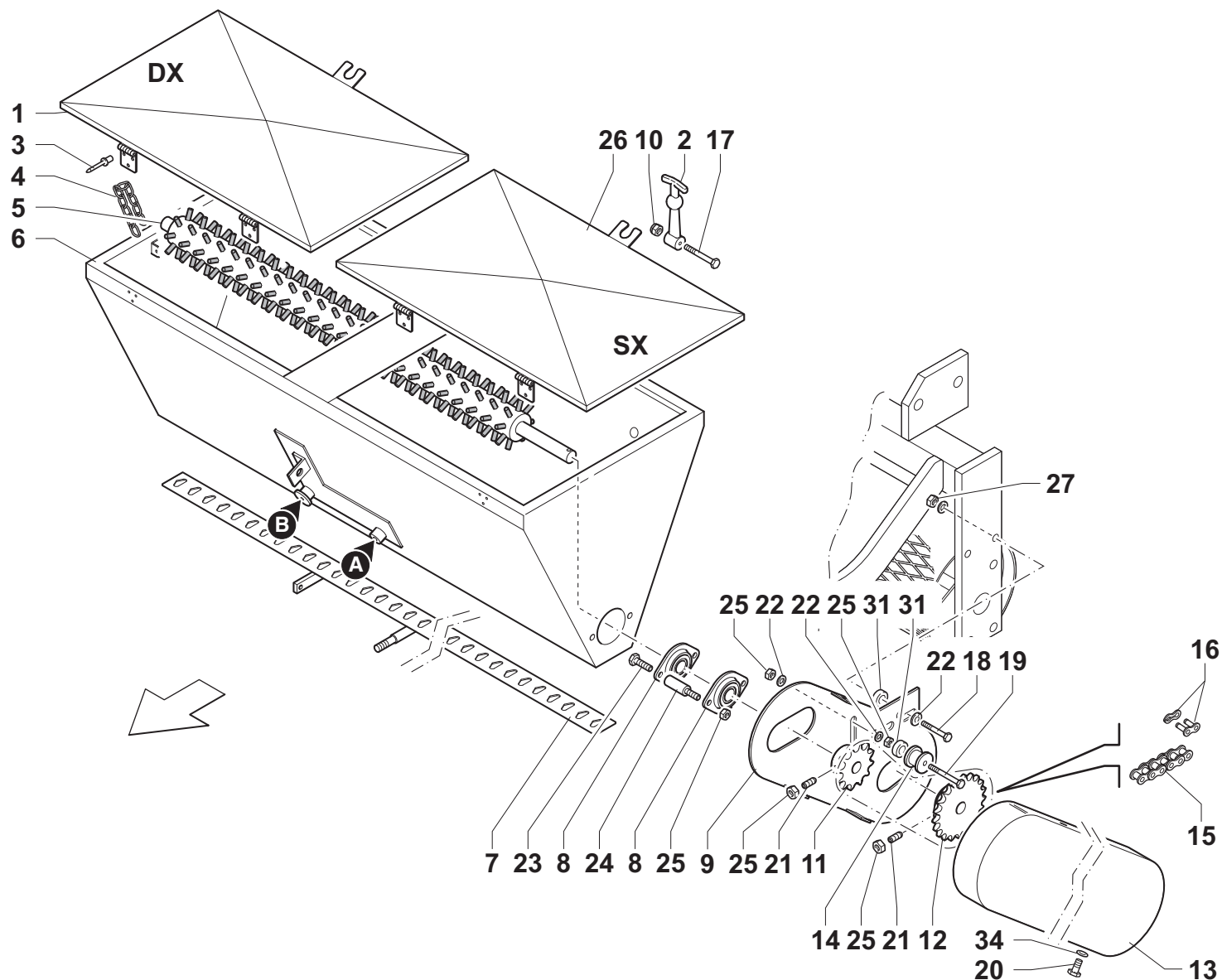
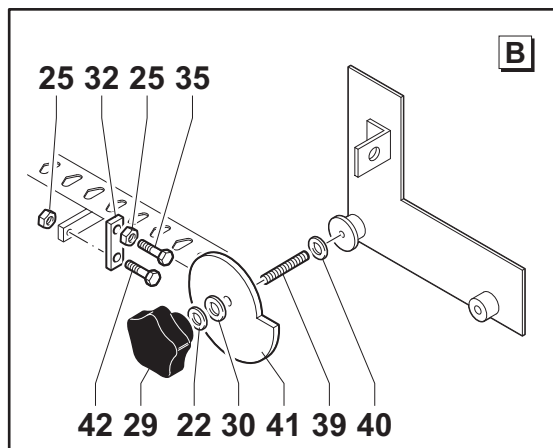
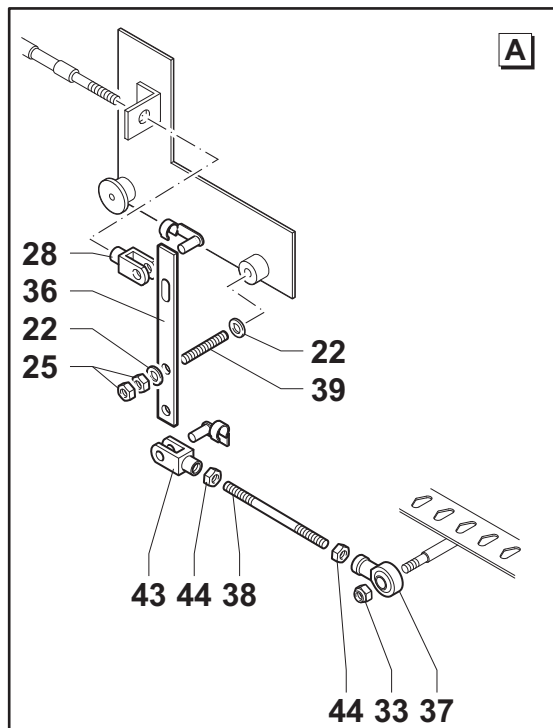

<b>Rif.</b>	<b>CODICE</b>	<b>Qty</b>	<b>Descrizione</b>	<b>Description</b>	<b>Designation</b>	<b>Benennung</b>	<b>Denominaciones</b>
20	21.0.0.05016	1	VITE	SCREW	VIS	SCHRAUBE	TORNILLO
21	25.2.1.08020	2	GRANO	SECURITY DOWEL	GRAIN	STIFT	PERNO DE TOPE
22	15.1.0.00.008	6	RONDELLA PIANA	PLAIN WASHER	RONDELLE PLANE	ABSTANDSRING	ARANDELA LLANA
23	21.0.0.08016	4	VITE	SCREW	VIS	SCHRAUBE	TORNILLO
24	036.154	2	DISTANZIALE	SPACER	ENTRETOISE	ABSTANDSTUECK	SEPARADOR
25	31.02.00.0.08	9	DADO AUTOBLOCCANTE	STOP NUT	ECROU DE SURETE	SPERRMUTTER	TUERCA AUTOTRABADORA
26	036.004/SX	2	COPERCHIO SM-120	COVER	COUVERCLE	DECKEL	TAPA
26	036.006/SX	2	COPERCHIO SM-135	COVER	COUVERCLE	DECKEL	TAPA
26	036.138/SX	2	COPERCHIO SM-150	COVER	COUVERCLE	DECKEL	TAPA
26	036.142/SX	2	COPERCHIO SM-170	COVER	COUVERCLE	DECKEL	TAPA
27	30.02.00.008	2	DADO AUTOBLOCCANTE	STOP NUT	ECROU DE SURETE	SPERRMUTTER	TUERCA AUTOTRABADORA
28	050.070	1	FORCELLA	FORK	FOURCHE	GABEL	HORQUILLA
29	050.030	1	POMELLO	BALL-GRIP	POMMEAU	KUGELGRIFF	POMO
30	050.071	1	RONDELLA TEFLON	TEFLON WASHER	RONDELLE TEFLON	TEFLON-SCHEIBE	ARANDELA TEFLON
31	036.205	1	DISTANZIALE	SPACER	ENTRETOISE	ABSTANDSTUECK	SEPARADOR
32	036.068	1	PIATTO FORATO	PLATE	PLATEAU	TELLER	DISCO
33	30.02.01.008	1	DADO AUTOBLOCCANTE	STOP NUT	ECROU DE SURETE	SPERRMUTTER	TUERCA AUTOTRABADORA
34	15.0.0.00.005	1	RONDELLA PIANA	PLAIN WASHER	RONDELLE PLANE	ABSTANDSRING	ARANDELA LLANA
35	20.0.0.08035	1	VITE	SCREW	VIS	SCHRAUBE	TORNILLO
36	036.064	1	PIATTO FORATO	PLATE	PLATEAU	TELLER	DISCO
37	050.263	1	SNODO SFERICO	BALL JOINT	JOINT A ROTULE	KUGELGELENK	ARTICULACION DE BOLA
38	045.041	1	BARRA FILETTATA	THREADED BAR	BARE FILETEE	STANGE SCHRAUBEN	BARRA FILETEAR
39	26.0.0.08025	2	PRIGIONIERO	STUD	PRISONNIER	GEWINDESTIFT	PRISIONERO
40	050.072	1	RONDELLA PIANA	PLAIN WASHER	RONDELLE PLANE	ABSTANDSRING	ARANDELA LLANA
41	036.066	1	CAMMA REGOLAZIONE	ADJUSTMENT CAM	CAME DE REGLAGE	EINSTELLNOCKEN	LEVA DE AJUSTE
42	21.0.0.08025	1	VITE	SCREW	VIS	SCHRAUBE	TORNILLO
43	050.069	2	FORCELLA	FORK	FOURCHE	GABEL	HORQUILLA
44	31.02.00.008	4	DADO	NUT	ECROU	MUTTER	TUERCA





**MONTAGGIO RULLO POSTERIORE (SM 100-120)**  
REAR ROLLER ASSEMBLY (SM 100-120)  
MONTAGE ROULEAUX ARRIERE (SM 100-120)  
MONTAGE HINTERE ROLLEN (SM 100-120)  
MONTAGE RODILLOS TRASERO (SM 100-120)

MTZ / MTZ<sub>HI</sub>

**Tav. 03.0**

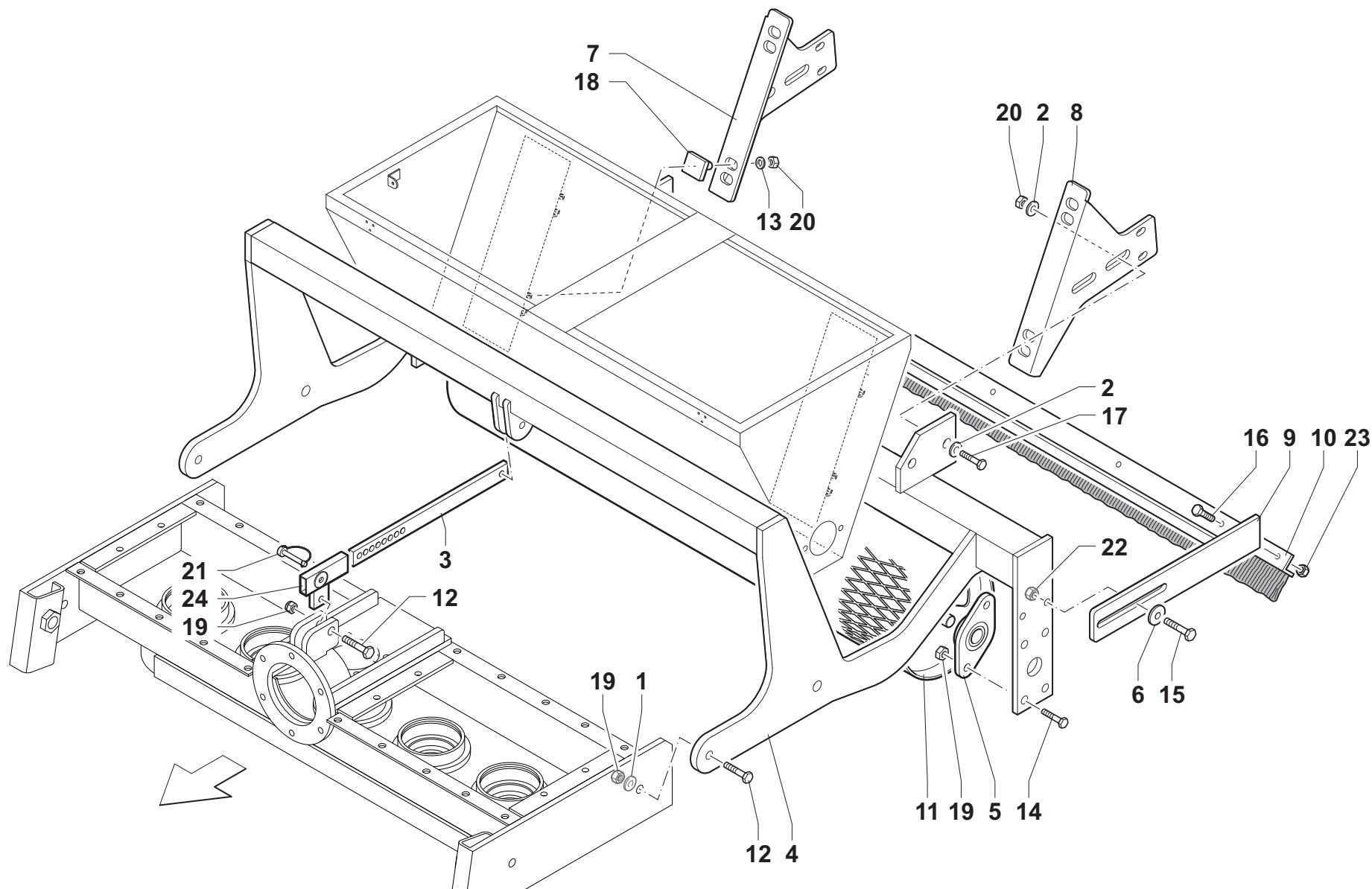

<i>Rif.</i>	<i>CODICE</i>	<i>Qty</i>	<i>Descrizione</i>	<i>Description</i>	<i>Designation</i>	<i>Benennung</i>	<i>Denominaciones</i>
1	15.1.0.00.010	2	RONDELLA PIANA	PLAIN WASHER	RONDELLE PLANE	ABSTANDSRING	ARANDELA LLANA
2	15.1.0.00.012	8	RONDELLA PIANA	PLAIN WASHER	RONDELLE PLANE	ABSTANDSRING	ARANDELA LLANA
3	036.085	1	TIRANTE	TIE ROD	TIRANT	SPANNSTANGE	TIRANTE
4	036.013	1	SUPPORTO RULLO SM-120	SUPPORT	SUPPORT	LAGER	SOPORTE
4	036.029	1	SUPPORTO RULLO SM-100	SUPPORT	SUPPORT	LAGER	SOPORTE
5	UCFL204	2	SUPPORTO	SUPPORT	SUPPORT	LAGER	SOPORTE
6	15.1.0.00.008	4	RONDELLA PIANA	PLAIN WASHER	RONDELLE PLANE	ABSTANDSRING	ARANDELA LLANA
7	036.080/D	1	SUPPORTO CASSONETTO DX	RIGHT BOX SUPPORT	SUPPORT COFFRE DROIT	KASTENHALTERUNG RECHTS	SOPORTE CAJA DERECHA
8	036.080/S	1	SUPPORTO CASSONETTO SX	LEFT BOX SUPPORT	SUPPORT COFFRE GAUCHE	KASTENHALTERUNG LINKS	SOPORTE CAJA IZQUIERDA
9	036.029	1	SUPPORTO SPAZZOLA SM-100	BRUSH SUPPORT	SUPPORT BROSSE	BÜRSTENTRÄGER	SOPORTE CEPILLO
9	036.035	1	SUPPORTO SPAZZOLA SM-120	BRUSH SUPPORT	SUPPORT BROSSE	BÜRSTENTRÄGER	SOPORTE CEPILLO
10	036.047	1	SPAZZOLA SM-100	BRUSH	BROSSE	BUERSTE	CEPILLO
10	036.049	1	SPAZZOLA SM-120	BRUSH	BROSSE	BUERSTE	CEPILLO
11	036.023	1	RULLO SM-100	ROLLER	ROULEAU	WALZE ROLLE	RODILLO
11	036.103	1	RULLO SM-120	ROLLER	ROULEAU	WALZE ROLLE	RODILLO
12	21.0.0.10045	4	VITE	SCREW	VIS	SCHRAUBE	TORNILLO
13	15.0.0.00.012	4	RONDELLA PIANA	PLAIN WASHER	RONDELLE PLANE	ABSTANDSRING	ARANDELA LLANA
14	20.0.0.10035	4	VITE	SCREW	VIS	SCHRAUBE	TORNILLO
15	21.0.0.08030	4	VITE	SCREW	VIS	SCHRAUBE	TORNILLO
16	21.0.0.06020	-	VITE	SCREW	VIS	SCHRAUBE	TORNILLO
17	20.0.0.12040	4	VITE	SCREW	VIS	SCHRAUBE	TORNILLO
18	036.086	4	PIATTO	PLATE	PLATEAU	TELLER	DISCO
19	30.02.00.010	8	DADO AUTOBLOCCANTE	STOP NUT	ECROU DE SURETE	SPERRMUTTER	TUERCA AUTOTRABADORA
20	30.02.01.012	8	DADO AUTOBLOCCANTE	STOP NUT	ECROU DE SURETE	SPERRMUTTER	TUERCA AUTOTRABADORA
21	050.004	1	COPIGLIA	COTTER PIN	GOUPILLE	SPLINT	CLAVIJA
22	30.02.00.008	4	DADO AUTOBLOCCANTE	STOP NUT	ECROU DE SURETE	SPERRMUTTER	TUERCA AUTOTRABADORA
23	30.02.00.006	-	DADO AUTOBLOCCANTE	STOP NUT	ECROU DE SURETE	SPERRMUTTER	TUERCA AUTOTRABADORA
24	000.009	1	GUIDA	GUIDE	GUIDE	FÜHRUNG	GUIA



MTZ / MTZ<sub>HI</sub>

**Tav. 03.0**





**MONTAGGIO RULLO POSTERIORE (SM 135-150-170)**  
REAR ROLLER ASSEMBLY (SM 135-150-170)  
MONTAGE ROULEAUX ARRIERE (SM 135-150-170)  
MONTAGE HINTERE ROLLEN (SM 135-150-170)  
MONTAGE RODILLOS TRASERO (SM 135-150-170)

MTZ / MTZ<sub>HI</sub>

**Tav. 04.0**

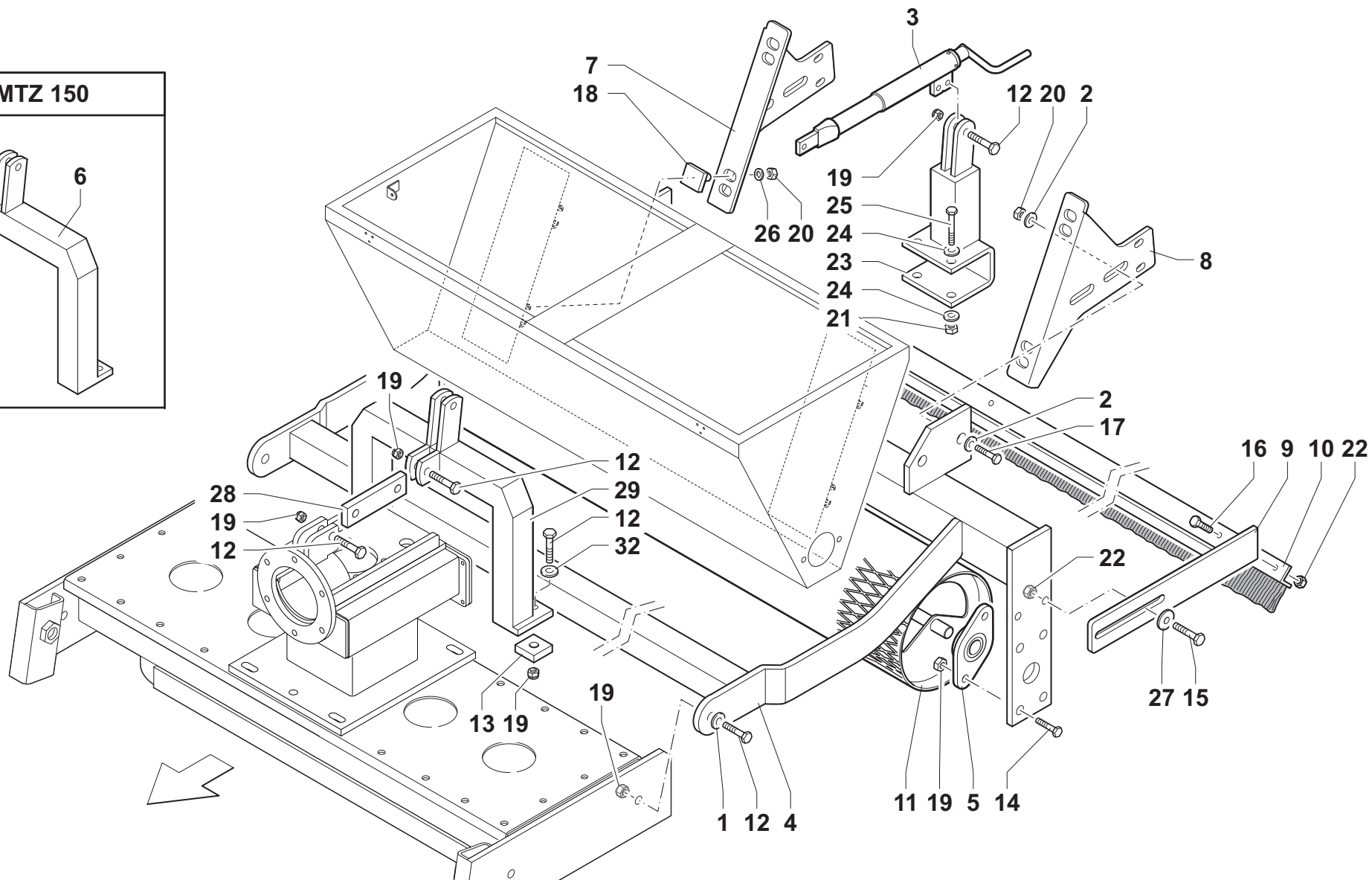
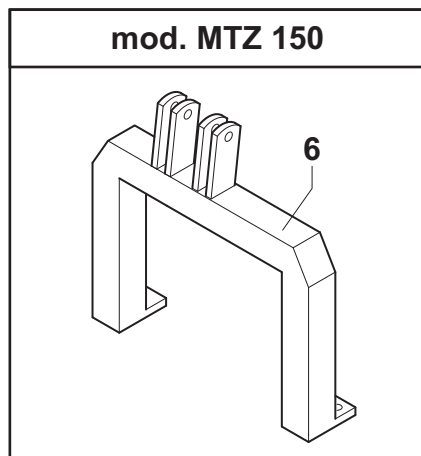



<i>Rif.</i>	<i>CODICE</i>	<i>Qty</i>	<i>Descrizione</i>	<i>Description</i>	<i>Designation</i>	<i>Benennung</i>	<i>Denominaciones</i>
1	15.1.0.00.010	2	RONDELLA PIANA	PLAIN WASHER	RONDELLE PLANE	ABSTANDSRING	ARANDELA LLANA
2	15.1.0.00.012	8	RONDELLA PIANA	PLAIN WASHER	RONDELLE PLANE	ABSTANDSRING	ARANDELA LLANA
3	034.070/L	1	REGISTRO	ADJUSTER	REGLAGE	REGULATOR	AJUSTE
4	036.014	1	SUPPORTO RULLO SM-135	SUPPORT	SUPPORT	LAGER	SOPORTE
4	036.114	1	SUPPORTO RULLO SM-150	SUPPORT	SUPPORT	LAGER	SOPORTE
4	036.116	1	SUPPORTO RULLO SM-170	SUPPORT	SUPPORT	LAGER	SOPORTE
5	UCFL204	2	SUPPORTO	SUPPORT	SUPPORT	LAGER	SOPORTE
6	036.112/A	1	SUPPORTO SM-150	SUPPORT	SUPPORT	LAGER	SOPORTE
7	036.080/D	1	SUPPORTO CASSONETTO DX	RIGHT BOX SUPPORT	SUPPORT COFFRE DROIT	KASTENHALTERUNG RECHTS	SOPORTE CAJA DERECHA
8	036.080/S	1	SUPPORTO CASSONETTO SX	LEFT BOX SUPPORT	SUPPORT COFFRE GAUCHE	KASTENHALTERUNG LINKS	SOPORTE CAJA IZQUIERDA
9	036.036	1	SUPPORTO SPAZZOLA SM-135	BRUSH SUPPORT	SUPPORT BROSSSE	BÜRSTENTRÄGER	SOPORTE CEPILLO
9	036.037	1	SUPPORTO SPAZZOLA SM-150	BRUSH SUPPORT	SUPPORT BROSSSE	BÜRSTENTRÄGER	SOPORTE CEPILLO
9	036.038	1	SUPPORTO SPAZZOLA SM-170	BRUSH SUPPORT	SUPPORT BROSSSE	BÜRSTENTRÄGER	SOPORTE CEPILLO
10	036.050	1	SPAZZOLA SM-135	BRUSH	BROSSE	BUERSTE	CEPILLO
10	036.189	1	SPAZZOLA SM-150	BRUSH	BROSSE	BUERSTE	CEPILLO
10	036.190	1	SPAZZOLA SM-170	BRUSH	BROSSE	BUERSTE	CEPILLO
11	036.024	1	RULLO SM-150	ROLLER	ROULEAU	WALZE ROLLE	RODILLO
11	036.026	1	RULLO SM-135	ROLLER	ROULEAU	WALZE ROLLE	RODILLO
11	036.103	1	RULLO SM-170	ROLLER	ROULEAU	WALZE ROLLE	RODILLO
12	21.0.0.10045	7	VITE	SCREW	VIS	SCHRAUBE	TORNILLO
13	036.112B	1	SPESSORE	THICKNESS	EPAISSEUR	ZWISCHENLAGE	ESPEJOR
14	20.0.0.10035	4	VITE	SCREW	VIS	SCHRAUBE	TORNILLO
15	21.0.0.08030	4	VITE	SCREW	VIS	SCHRAUBE	TORNILLO
16	21.0.0.06020	-	VITE	SCREW	VIS	SCHRAUBE	TORNILLO
17	20.0.0.12040	4	VITE	SCREW	VIS	SCHRAUBE	TORNILLO
18	036.086	4	PIATTO	PLATE	PLATEAU	TELLER	DISCO
19	30.02.00.010	11	DADO AUTOBLOCCANTE	STOP NUT	ECROU DE SURETE	SPERRMUTTER	TUERCA AUTOTRABADORA
20	30.02.01.012	8	DADO AUTOBLOCCANTE	STOP NUT	ECROU DE SURETE	SPERRMUTTER	TUERCA AUTOTRABADORA
21	30.01.00.012	2	DADO AUTOBLOCCANTE	STOP NUT	ECROU DE SURETE	SPERRMUTTER	TUERCA AUTOTRABADORA
22	30.02.00.008	-	DADO AUTOBLOCCANTE	STOP NUT	ECROU DE SURETE	SPERRMUTTER	TUERCA AUTOTRABADORA
23	036.111	1	STAFFA	BRACKET	ETRIER	BUEGEL	ESTRIBO



MTZ / MTZ<sub>HI</sub>

**Tav. 04.0**



**MONTAGGIO RULLO POSTERIORE (SM 135-150-170)**  
REAR ROLLER ASSEMBLY (SM 135-150-170)  
MONTAGE ROULEAUX ARRIERE (SM 135-150-170)  
MONTAGE HINTERE ROLLEN (SM 135-150-170)  
MONTAGE RODILLOS TRASERO (SM 135-150-170)

MTZ / MTZ<sub>HI</sub>

**Tav. 04.0**

